



## breezeEV Level 2 Charging Station Install Guide – P80

BreezEV offers best-in-class hardware and technical support. If you have any questions during installation, please do not hesitate to contact us.



# Table of Contents

**Safety and Compliance** .....

**Before Installation, Please Read**

    Summary of Shipping Boxes .....

    Specifications .....

    Dimensions .....

    Wiring Diagram & Requirements.....

    Tools Required .....

**Wall-Mount Installation**

    Mechanical Installation.....

    Electrical Connections.....

**Status Descriptions on Charger**

    Normal .....

    Abnormal/Troubleshooting .....



# Safety and Compliance

## SAVE THESE SAFETY INSTRUCTIONS

This manual contains important instructions that must be followed during installation of a breezeEV Charging Station.

## WARNINGS

This manual contains important instructions for breezeEV EVC-L2 series that shall be followed during installation, operation, and maintenance of the unit.

1. Read all the instructions before using this product.
2. This device should be supervised when used around children.
3. Do not put fingers into the electric vehicle connector.
4. Do not use this product if the flexible power cord or EV cable is frayed, has broken insulation, or any other signs of damage.
5. Do not use this product if the enclosure or the EV connector is broken, cracked, open, or shows any other indication of damage.
6. To reduce the risk of fire, connect only to a circuit provided branch circuit over-current protection in accordance with the CSA C22.1–15 Canadian Electrical Code, Part 1 (Canada) or NOM-001-SEDE Electrical installations (utility) (Mexico) or ANSI / NFPA 70 National Electrical Code (USA).
7. To avoid a risk of fire or electric shock, do not use this device with an extension cord.
8. THE SUITABILITY OF THE USE OF FLEXIBLE CORD IN ACCORDANCE WITH CE CODE, PART I, RULE 4-012, IS TO BE DETERMINED BY THE LOCAL INSPECTION AUTHORITY HAVING JURISDICTION.
9. Risk of electric shock. Do not remove cover or attempt to open the enclosure. No user serviceable parts inside. Refer servicing to qualified service personnel.

**AVERTISSEMENT** – Ce manuel contient des instructions importantes pour les modèles: série EVC-L2 qui doit être suivie pendant l'installation, le fonctionnement et la maintenance de l'unité.

1. Lisez toutes les instructions avant d'utiliser ce produit.
2. Cet appareil doit être surveillé lorsqu'il est utilisé à proximité d'enfants.
3. Ne pas mettre les doigts dans le connecteur du véhicule électrique.
4. N'utilisez pas ce produit si le cordon d'alimentation flexible ou le câble EV est effiloché, a une isolation cassée, ou tout autre signe de dommage.
5. N'utilisez pas ce produit si le boîtier ou le connecteur EV est cassé, fissuré, ouvert ou montre toute autre indication de dommage.
6. Pour réduire les risques d'incendie, ne connecter qu'à un circuit protection contre les surintensités des circuits de dérivation conformément à la norme canadienne CSA C22.1-15 Code électrique, partie 1 (Canada) ou NOM-001-SEDE Installations électriques (service public) (Mexique) ou ANSI / NFPA 70 National Electrical Code (États-Unis).

## FCC Compliance Statement

This device complies with part 15 of the FCC Rules.

Operation is subject to the following two conditions:

1. This device may not cause harmful interference,
2. This device must accept any interference received, including interference that may cause undesired operation.

Caution: Changes or modifications to this unit not expressly approved by the party responsible for compliance could void the user's authority to operate the equipment.

Note: This equipment has been tested and found to comply with the limits for a Class A digital device, pursuant to part 15 of the FCC Rules. These limits are designed to provide reasonable protection against harmful interference when the equipment is operated in a commercial environment. This equipment generates, uses, and can radiate radio frequency energy and, if not installed and used in accordance with the instruction manual, may cause harmful interference to radio communications. Operation of this equipment in a residential area is likely to cause harmful interference in which case the user will be required to correct the interference at his own expense.

WiFi module: FCC ID:2AC7Z-ESPWROOM32D

LTE module: FCC ID: XMR202008EC25AFXD

To satisfy FCC RF exposure requirements, a separation distance of 20cm or more should be maintained between the antenna of this device and persons during device operation. To ensure compliance, operations at closer than this distance is not recommended.

## DESIGN STANDARDS FOLLOWED

The following UL testing & certification protocols have been followed:

- UL 2594: Electric Vehicle Supply Equipment
- UL 2231-1: Personnel Protection Systems for Electric Vehicle (EV) Supply Circuits: General Requirements
- UL 2231-2: Personnel Protection Systems for Electric Vehicle (EV) Supply Circuits: Requirements for Protection Devices for Use in Charging Systems
- UL 2251: Plugs, Receptacles and Couplers for Electric Vehicles
- UL 62: Flexible Cords and Cables
- UL 991: Tests for Safety-Related Controls Employing Solid-State Devices
- UL 1998: Software in Programmable Components
- NFPA 70 Article 625: National Electrical Code, Electric Vehicle Charging System
- UL 840 (Clearance and Creepage)

## WARRANTY STATEMENTS

Please see breezeEV Standard Limited Warranty & Ultimate-Guard Program Details, both located on our website.



## Summary of Shipping Boxes

### CHARGER

Part Name	Label/Part # on Box	Box Contents	Example Drawing/Image of Box Contents
Charger Kit	EVC-L2-P80-18	<ol style="list-style-type: none"> <li>Charger (QTY 1)</li> <li>User Manual (QTY 1)</li> <li>Wall-Mount Bracket (QTY 1)</li> <li>M5 Wall-Mount Bracket Screws (QTY 2)</li> <li>M6 Hexagonal Wall-Mount Bracket Expansion Screws (QTY 4)</li> </ol>	
Hardware Kit	EVC-L2-ACC-HARDWARE KIT	<ol style="list-style-type: none"> <li>Liquid tight for incoming power wires (QTY 2)</li> <li>Incoming power wires (QTY 3)</li> <li>Liquid tight fittings for incoming power cable &amp; charging cable (QTY 2)</li> <li>J1772 Holster (QTY 1)</li> <li>Mounting screws for J1772 Holster (QTY 4)</li> </ol>	

### CHARGING CABLE SET

Part Name	Label/Part # on Box	Box Contents	Example Drawing/Image of Box Contents
Charging Cable Set	80A cable included in the box	<ol style="list-style-type: none"> <li>Cable with J1772 plug on one end and crimped terminals on the other</li> </ol>	

### WET CONCRETE PEDESTAL ANCHOR KIT (only needed for wet concrete pours)

Part Name	Label/Part # on Box	Box Contents	Example Drawing/Image of Box Contents
Wet Concrete Pedestal Anchor Kit	EVC-L2-ACC-ANCHOR KIT WET	<ol style="list-style-type: none"> <li>Wet concrete J-bolts (QTY 4)</li> <li>Paper template (QTY 1)</li> </ol>	



## SPECIFICATIONS

Model Number	EVC10 Version
Rated Input Voltage	208/240VAC
Rated Output Current	16/32/40/48/70/80A
AC Power Frequency	50-60 Hz
Input Protection	UVP, OVP, RCD, SPD, Ground Fault Protection
Output Protection	OCP, OTP, Control Pilot Fault Protection
Output Interface	SAE J1772AC Charging Connector
Storage Temperature	-40°F to 158°F
Operation Temperature	-22°F to 122°F
Relative Operation Humidity	95% RH Maximum
Relative Storage Humidity	95% RH Maximum
Network Connection	LAN Version /Wi-Fi Version/4G version
Internet Function	10M / 100M Base-T
Wi-Fi Function	802.11 b/g/n
3G/4G Function	GSM/3G/4G
Cable Length	18ft (25ft optional)
Protection Level	Type 3
Installation Type	Wall-Mounted
Altitude	≤6561ft
Status Indication	Red, Green, Blue LED



## DIMENSIONS

### Enclosure

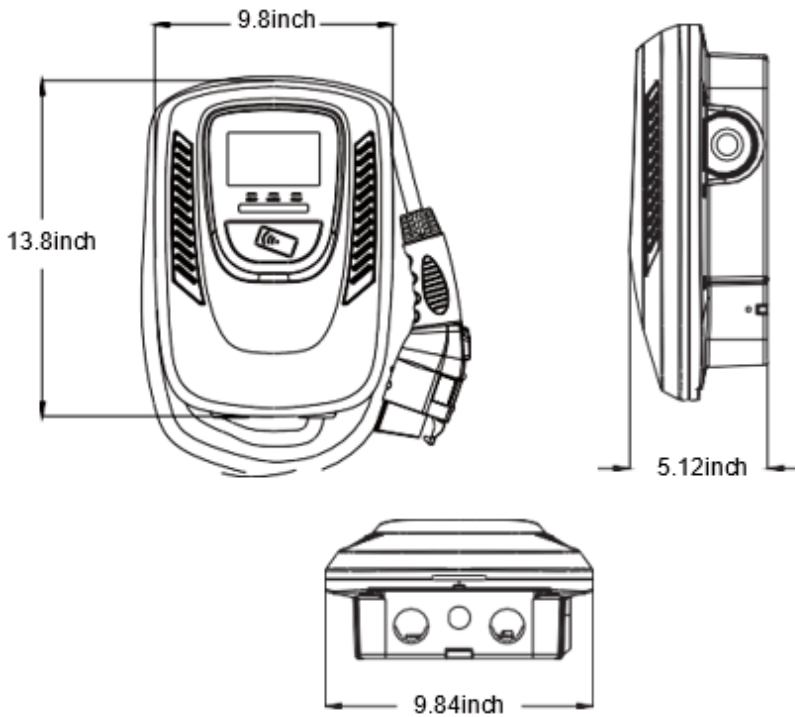

### Wall-Mounted Bracket

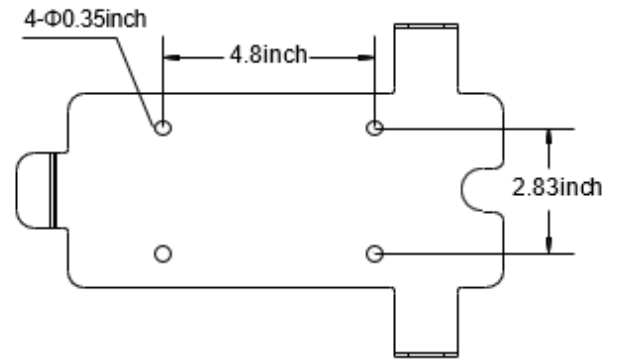

# WIRING DIAGRAM & REQUIREMENTS

## Key Requirements

1. EV charging stations shall be on a dedicated electrical circuit.
2. Each station shall be protected with a 2-pole common trip circuit breaker (non-GFCI type) as indicated by the below table:

Circuit Breaker Options table						
Output Amperage (A)	16A	32A	40A	48A	70A	80A
Circuit Breaker Options (A)	20A	40A	50A	60A	90A	100A

3. If a pedestal with 2 chargers is installed with a single feed, the circuit breaker must be rated at 2X the options listed in the table above.
4. Each station is designed to draw a maximum of 80 amps.
5. Each station can operate on either a 240V or 208V circuit.
6. Each station requires three electrical supply wires (two hot, one ground, no neutral).

## Wiring Diagram

Connect breezeEV stations to any one of the power sources as shown:

1. 208 VAC three phase, Delta system, Center tap grounded (use only two phases)
2. 208 VAC three phase, Wye system (use only two phases)
3. 240 VAC single phase

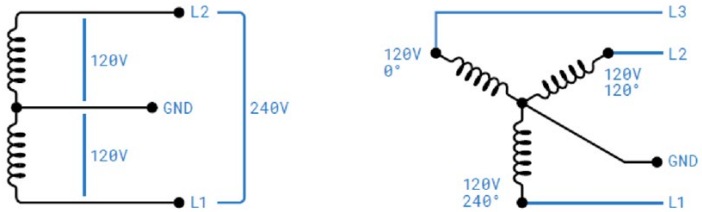

In a delta system, connect the breezeEV station only to a center-tapped grounded transformer only as shown below. Connect the station to the side where ground is bonded (in figure C line A and C). This allows voltages to remain constant regardless of other loads that may be using the lines. Please do not connect to other type of power sources shown below.

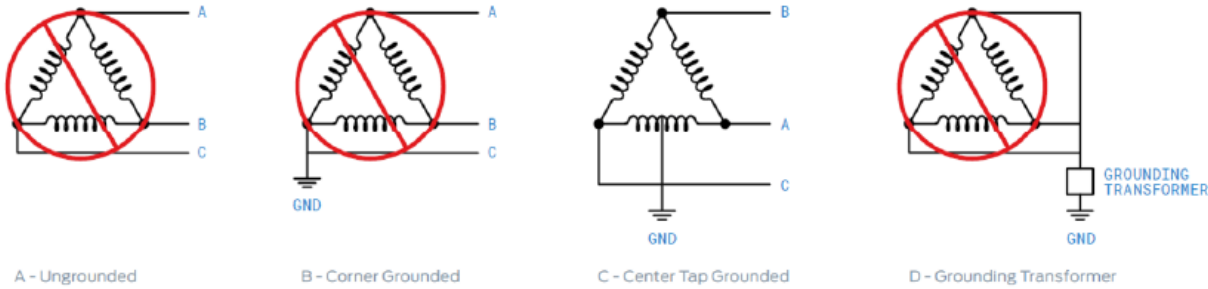



## TOOLS REQUIRED

Tools required before installing the Wall-Mounted charger, gather the following tools:

1. Wire stripper
2. Adjustable Wrench
3. Voltmeter or digital multi-meter (for measuring AC voltage at the installation site)
4. Level
5. Pencil or marker
6. Drill
7. Phillips screwdriver



1



2



3



4



5



6



7





## WALL-MOUNT INSTALLATION

### STEP 1

Use 4 sets Hexagonal Expansion Screws to secure the wall-mounted bracket on the wall. Then level the brackets.

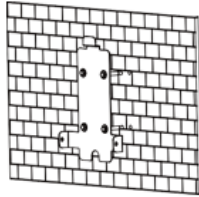

### STEP 2

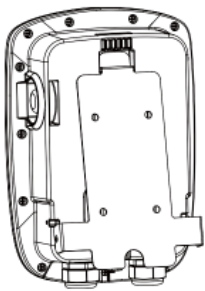

Align the rear notch of charger with the wall-mounted bracket and fit the screw holes of the right and left side.

### STEP 3



Tighten two M5 anti-theft screws to complete the installation.

### STEP 4

Overall outlook picture after installation.

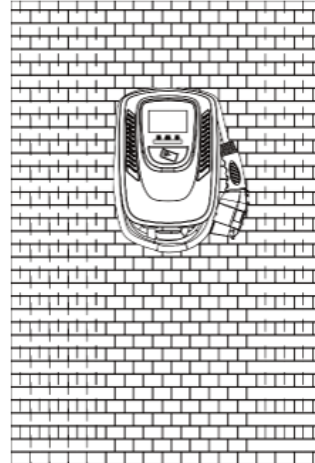

Wall-mounted cable winding

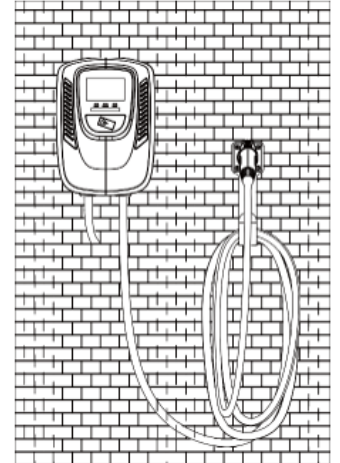

Optional cable hanging (optional accessory)

## Electrical Connections

### GROUNDING INSTRUCTIONS

This product must be grounded. If it should malfunction or break down, grounding provides a path of least resistance for electric current to reduce the risk of electric shock. This product is equipped with a cord having an equipment grounding conductor and a grounding plug. The plug must be plugged into an appropriate outlet that is professionally installed and grounded in accordance with all local codes and ordinances.

**WARNING** – Improper connection of the equipment-grounding conductor could result in the risk of electric shock. Check with a qualified electrician if you are in doubt as to whether the product is properly grounded.

**AVERTISSEMENT** - Une mauvaise connexion du conducteur de mise à la terre de l'équipement peut entraîner un risque de choc électrique. Vérifiez auprès d'un électricien ou d'un technicien qualifié si vous n'êtes pas sûr que le produit soit correctement mis à la terre. Ne modifiez pas la fiche fournie avec le produit - si elle ne rentre pas dans la prise, faites installer une prise appropriée par un électricien qualifié.



## P80 INPUT WIRING

 VEHICLE  
CHARGERS

The breezeEV P80 charger comes with current sensing loops that must be wired correctly for the charger to function.

1. Make sure electricity is off or not connected to the unit.
2. Open the cover
3. Connections require ring terminals on the conductors
4. Ensure the conductors are properly sized for the amperage and length of run based on the electrical code.
5. Install the ground wire to the **PE** terminal on the bottom left of the circuit board, **DO NOT** run it through the current sensing loop.
6. Run the two power wires through the 30mA current sensing loop and then to L1\_IN & L2\_IN
7. Install the cable clamp, clamp may be flipped to secure the conductors.
8. Run L1 from the vehicle cable through the 100A current sensing loop into L1\_OUT.
9. Close the cover

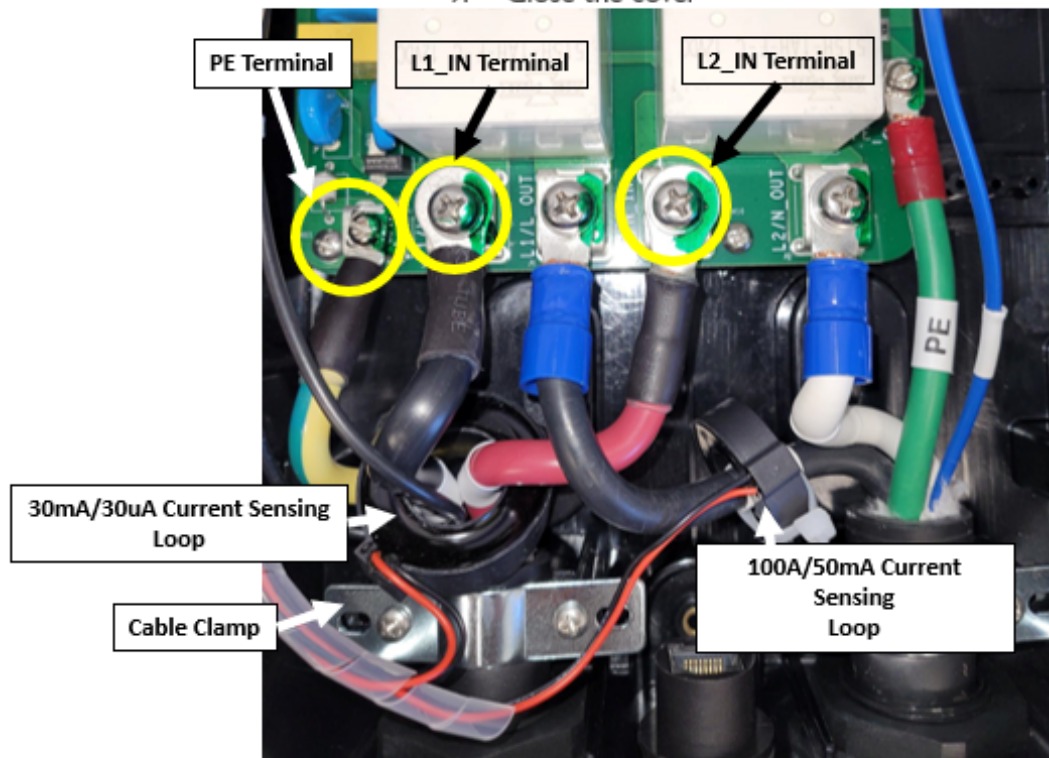



## Status Descriptions on Charger

Standby, waiting to plug in	Waiting to charge, communicating with vehicle	Charging in progress	Finished charging	Fault
Solid Blue	Solid Green	Green Blinking	Solid Green	Solid Red

## Errors and warning messages:

Status	Red	Remark
Input OVP	1 flashes followed by 3 sec pause	Auto Recover
Input UVP	2 flashes followed by 3 sec pause	Auto Recover
Output OCP	3 flashes followed by 3 sec pause	Auto Recover
OTP	4 flashes followed by 3 sec pause	Auto Recover
RCD Abnormal	5 flashes followed by 3 sec pause	Auto Recover
Ground Fault	6 flashes followed by 3 sec pause	Auto Recover
Control Pilot Fault	Flicker	Auto Recover
Emergency Fault	Constantly Bright	Rotate to Reset Emergency Button
MCU Self-Test Fail	Constantly Bright	Contact Customer Service
RCD Self-Test Fail	Constantly Bright	Contact Customer Service
Relay Self-Test Fail	Constantly Bright	Contact Customer Service
RCD Abnormal Stop Charging	Constantly Bright	Contact Customer Service
Output OCP Stop Charging	Constantly Bright	Contact Customer Service
OTP Stop Charging	Constantly Bright	Contact Customer Service